



Project
MUSE[®]

Today's Research. Tomorrow's Inspiration.

Videogames in Computer Space: The Complex History of Pong

Henry Lowood

IEEE Annals of the History of Computing, Volume 31, Number 3, July-September 2009, pp. 5-19 (Article)

Published by IEEE Computer Society



 For additional information about this article

<http://muse.jhu.edu/journals/ahc/summary/v031/31.3.lowood01.html>

Videogames in Computer Space: The Complex History of Pong

Henry Lowood
Stanford University

The earliest digital games emerged out of laboratories and research centers in the 1960s and 1970s. The intertwined histories of Nolan Bushnell's Computer Space and Pong illustrate the transition from these "university games" to accessible entertainment and educational games as well as the complicated historical relationship among the arcade, computer, and videogames.

Computer games such as *Spacewar!* and *Adventure* were created in institutions, such as the Massachusetts Institute of Technology, BBN, and Stanford University, that defined the main streams of computing research during the 1960s and 1970s.¹ Telling the stories of these games reveals the emergence of "university games" out of laboratories and research centers.² The institutional contexts of *Spacewar* and *Adventure* suggest an important, and at times underappreciated, relationship between exploratory work in computer science and the early history of computer games. Both games grew out of the very institutions that played an essential role in defining time-shared and then networked computing in its early days. Games such as these exemplified the technical mastery of programmers and hardware hackers. These links between games and computing recall Brian Sutton-Smith's argument that games are fundamentally "problems in adaptation" and that computer games specifically address the problem that "is the computer."³

A success story that marked the early evolution of the videogame, Atari's original *Pong* arcade console betrays few obvious connections to computer technology of the mid-1970s. The prototype's cabinet and circuitry, designed by *Al Alcorn*, reveal only a modest investment in electronic components, a modified television set, and some ad hoc wiring and parts. Years later, Alcorn made a block diagram of the game's logic for a later generation of computer science students less familiar with tricks of transistor-transistor logic (TTL); it shows the circuitry that generated game control functions as well as video signals to produce the game's images and

sounds (see Figure 1). **The original game ran not one line of program code.** It did not use a microprocessor or a custom integrated circuit; rather, it was a digital logic design made from components familiar to a television engineer who thoroughly understood the various ways pulse waveforms could be generated and manipulated.

Despite being constructed entirely from television technology, *Pong* is occasionally depicted as a product of the computer age or even as a computer artifact. One of the earliest critical studies of videogames, Geoffrey R. Loftus and Elizabeth F. Loftus' *Mind at Play* described *Pong* as being "entirely under the control of a computer," and their version of the videogame's "family tree" showed arcade games and digital computing as its parents. Michael Malone wrote in his excellent history of Silicon Valley that *Pong* was put together by a computer programmer.⁵ These mischaracterizations of *Pong* reflect a natural, if perhaps careless, assumption about the dawn of the videogame. If much of its past—and, as we now know, its future—was bound to the computer, we are tempted to read these connections into every videogame artifact. Like the theory of pre-formation in the 18th century, this idea leads us to see a fully formed adult in the germ of origin, a little computer inside every game machine.

The relationship of *Pong*'s creators at Atari to computer technology has not yet been investigated in a manner that illuminates the connections, if any, between early computer games and videogames. On the face of it, there would seem to be no particular connection, at least nothing that can be traced in the particular technologies involved; the

Simplified Block Diagram Pong

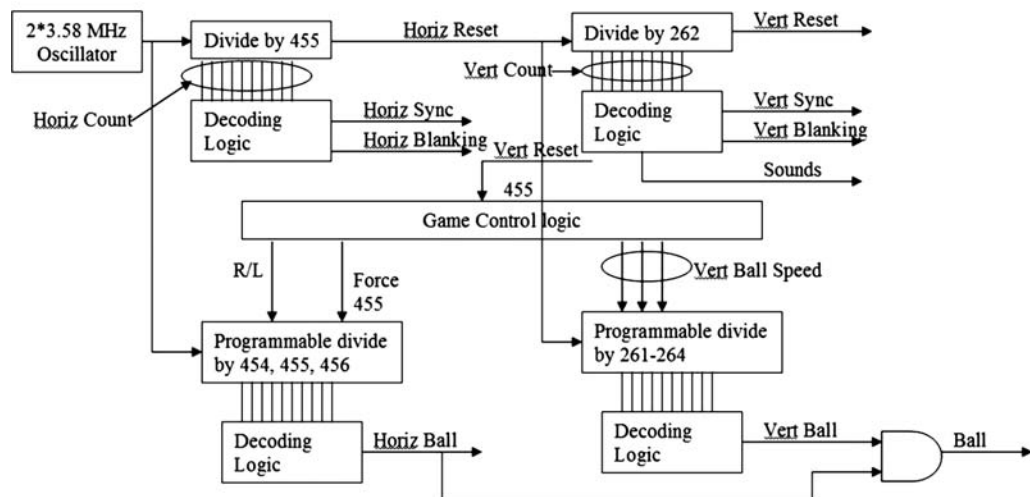
Figure 1. Al Alcorn's simplified block diagram for Pong.⁴

convergence certainly cannot be found inside the original *Pong* arcade console. The relationship might have played out in other ways, however, that might better be described in terms of influence rather than convergence. The reading of *Pong* as a product of the computer age sidesteps the emergence of the videogame out of TV engineering, but it also calls attention to other factors in the development of the new videogame technology—what the key figures had in mind, their entrepreneurial aspirations, their specific engineering training, and the impact of subsequent litigation on the story.

Pong was an easy game to play, a definite competitive advantage for an arcade game often placed in bars and restaurants where a patron could play with a drink in one hand. Has its simplicity discouraged serious attention to its history? This first success story of the commercial videogame has deflected critical reflection through reduction to a “keep it simple, less is more” narrative. According to this argument, *Pong* succeeded in a manner that requires little explanation; it was easy to learn and fun to play, providing uncomplicated amusement suited to taverns and arcades.⁶ End of story.

But what about the antecedents that set up its success? Nolan Bushnell's guiding vision of an electronic arcade game inspired by computer technology and previous work in TV game technology do not figure much in the explanation that *Pong* succeeded only because of its design simplicity. Hindsight and the appeal of a good Silicon Valley

success story have perhaps postponed deeper investigation of how the earliest commercial videogames were envisioned and built.⁷ In fact, *Pong* emerged from a complex of research projects, product design, and business relationships that later figured in heated legal and corporate disputes about intellectual property, priority of invention, and so on through the 1980s.⁸

This history of *Pong* begins with its problematic connection to computer-based games such as *Spacewar*. These games inspired Bushnell's industrial design project, *Computer Space*. Tracking how that inspiration led to *Pong* corrects other accounts of the relationship between the TV game console and computer technology. Claims put forward in the courtroom, for example, attempted to portray computer games as a prior art of TV game technology. These disputes usually had little to do with *Pong* but were about rights and licenses associated with the invention of the television game and the reduction to practice of the relevant technology. In any case, the argument for computer games as prior art failed to make this case persuasively, as evidenced by settlements that benefited the holders for the original Baer/Harrison/Rusch TV game patents, assigned to Sanders Associates [now BAE Systems] and licensed to first Magnavox, and later Philips (pp. 157–161).⁹ As for Atari, it is fair to say that no other company of the early videogame era negotiated as many contradictions and convergences of computer and TV technology, which besides developing *Pong*

also manufactured arcade games, dedicated home consoles, programmable game machines, and home computers. The path of invention, innovation, and design that led to *Pong* reveals points both of intersection and disconnection between computer and TV technology during the videogame's early development.

Spacewar

The winding path from the computer to *Pong* began with *Spacewar*. Few computer games are linked so tightly with the technical and institutional contexts of digital computing. Steve Russell, Alan Kotok, J. Martin Graetz, and others at MIT created *Spacewar* in February 1962 to demonstrate the new PDP-1 minicomputer and Precision CRT Display Type 30, both donated by the Digital Equipment Corporation (DEC) to the Electrical Engineering Department only months earlier.¹⁰ The *Spacewar* authors were part of the Tech Model Railroad Club (TMRC) on campus, and *Spacewar* became an integral part of that culture. They were unimpressed by the "little pattern-generating programs" that others had made to show off the PDP-1, assuming more could be done with "this display that could do all sorts of good things!"¹¹

The group decided that the most interesting demonstration of the computer's capabilities would be "a two-dimensional maneuvering sort of thing, and . . . that naturally the obvious thing to do was spaceships."¹¹ They were guided by several principles for a good demo program, especially that "it should involve the onlooker in a pleasurable and active way—in short, it should be a game."¹² Russell led the project, influenced by earlier computer programs such as *Tic-Tac-Toe* and Marvin Minsky's Tri-Pos: Three Position Display, better known as the Minskytron. Russell's collaborators contributed code and built control boxes so that players could maneuver virtual spaceships around on the CRT and shoot at their opponents. The code was available to all hackers at MIT, who improved, extended, and modified the game. Peter Samson, offended by the sparse background of empty space, coded "Expensive Planetarium" to portray accurately the stars in the night sky; Dan Edwards worked on gravity calculations; Graetz programmed explosions; and so on. The game superbly showcased the lab's new computer, while stimulating better understanding of new graphics, I/O, and display technology. In April 1962, soon after *Spacewar* was unveiled, J.M. Graetz, the editor of

Decuscope, wrote that the "use of switches to control apparent motion of displayed objects amply demonstrates the real-time capabilities of the PDP-1." He had visited the computer room and could "verify an excellent performance" for the emerging PDP community.¹³

Spacewar thus demonstrated not only computing technology, but the technical mastery of programmers and hardware hackers as well. It expressed their shared culture and institutional setting. In working out the game, Russell fixed on the popular science fiction novels of Edward Elmer Smith's Lensman series. This was the early Space Age, so it is not surprising that a fan and hacker would place his game in the world of these novels. Smith's writing excelled at portraying action and movement, with spaceships blasting away at each other, so what better homage than a fast-paced shoot'em-up action game?

Setting it in outer space only required a visual backdrop of flickering stars that was relatively easy to render graphically because the Type 30's display could directly plot stars as points. Having an essentially dark background and a fantasy setting meant that the game's visual treats, spaceships and missiles, could be set in an appropriate visual space without overburdening the hardware. Russell noted also that,

by picking a world which people weren't familiar with, we could alter a number of parameters of the world in the interests of making a good game and of making it possible to get it onto a computer.¹¹

For example, Edwards' gravity calculations were realistic, but the programmers decreed that "photon torpedoes" ignored gravitational attraction to ease the computational task. Collaboration and design flexibility became the project's defining characteristics, much like the nascent culture of the computer lab.

Spacewar was distinctly a product of MIT computing. Like Whirlwind, the TX-0, and the PDP-1, it exemplified the tradition of what Gordon Bell has called "MIT personal computers."¹⁴ The gift of the PDP-1 established DEC as a provider of equipment for academic research, and *Spacewar* returned the favor. Freely distributed via paper tape in the lab, the game was shipped by DEC with PDP computers as a test program to verify their operation after new installations. *Spacewar* became a fixture in university and industrial laboratories of the 1960s and 1970s.

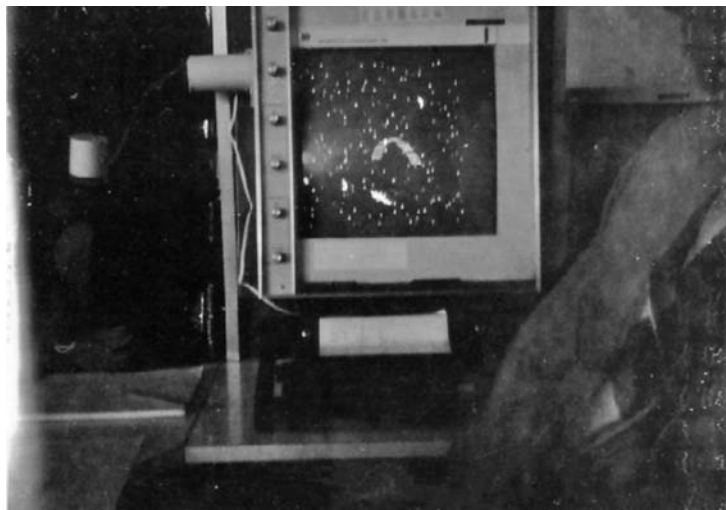

Figure 2. *Spacewar* at the Stanford AI Lab. (Courtesy of Stanford University, <http://infolab.stanford.edu/pub/voy/museum/pictures/Allab/list.html>.)

A community of programmers and players formed around it as a popular and competitive entertainment, described in Brand's reports of the 1972 *Spacewar* Olympics at Stanford (see Figure 2). Programmers everywhere added elements to the game or tweaked settings and controls in a local version. *Rolling Stone* reported, "within weeks of its invention *Spacewar* was spreading across the country to other computer research centers [that] began adding their own wrinkles."¹¹ This convergence of competitive skill, programming wizardry, and collaborative community characterized hacker culture.

Computer Space

How did *Spacewar* extend its influence from the TMRC hackers to the design of products such as arcade consoles? With the growth of a network of research laboratories funded by DARPA, especially its Information Processing Techniques Office (IPTO), a generation of computer science students was introduced to computers such as DEC's PDP series that ran *Spacewar*. One of these laboratories was at the University of Utah, home of a strong program in computer graphics that DARPA generously funded. One historian of computer graphics has remarked that, "almost every influential person in the modern computer-graphics community either passed through the University of Utah or came into contact with it in some way," while DARPA historians have called its program

"especially influential in the birth and development of interactive graphics."¹⁵

Nolan Bushnell graduated in 1968 from the University of Utah with a degree in electrical engineering. While there, he had access to the program's computers, and like many other students, he often played *Spacewar*. He also held a summer job as an amusement park employee, staffing a pinball arcade and other attractions. This unusual exposure to both carnival and computer culture stimulated his notion of creating a new kind of entertainment arcade filled with *Spacewar*-like games.

After graduating, he moved to California to work for Ampex, a leader in the development of magnetic recording, video, and computer storage technologies. He was now in the hotbed of high-technology entrepreneurship, at the southern boundary of the region Don Hoefler began calling "Silicon Valley U.S.A." in 1971.¹⁶ The first big wave of Silicon Valley start-ups crested between 1967 and 1969, with the founding of National Semiconductor, Intel, Advanced Micro Devices, and many more companies. Bushnell's entrepreneurial imagination responded to this environment. Surrounded by first-rate research engineers and product development teams at Ampex, he thought more about his vision of a *Spacewar* arcade. He was in the right place to ponder the impact of component miniaturization and integration. Moreover, located in Redwood City, Ampex was a short drive from a hotbed of *Spacewar* activity in Stanford University's Artificial Intelligence Laboratory (SAIL), an important center for computer science research.¹¹ Bushnell revived his enthusiasm for the game and pondered how money could be made in the arcade videogame business.

Bushnell's original plan was to create an arcade videogame based on *Spacewar* using a "Data General 1600—to have a minicomputer running multiple games."¹⁷ Having played *Spacewar* and used time-sharing systems at Utah and Stanford, Bushnell started out with the ambitious goal of creating an arcade system that utilized a time-sharing environment to display interactive graphics concurrently on several consoles. Although the concept was understandable, it was not feasible. In terms of cost, DEC's 36-bit, multitasking PDP-10/DEC System-10 had begun shipping to computer science departments in 1968, but a complete system cost well in excess of \$100,000—far more with displays, disk storage, printers, and hardware peripherals. Still, Bushnell was determined to create a modestly

priced computer arcade game inspired by *Spacewar*, a commitment underscored by calling this project Computer Space.

Key events related to the story of *Computer Space*—Bushnell’s departure from Ampex in March 1971, his partnership with Ted Dabney, the decision to join Nutting & Associates, which acquired and manufactured *Computer Space*, and the founding of Atari (originally called Syzygy) in June 1972—have been well documented.^{6,17–21} Less has been written about the technical and cultural contexts of Bushnell and Dabney’s work on *Computer Space*.

While still at Ampex, Dabney and Bushnell began to consider how to build an arcade version of the six-figure computing platforms used to play *Spacewar*. In the early 1970s, the steady progress of hardware miniaturization and software innovation sounded the call to deliver computing technology in smaller packages for many applications, so *Computer Space* can be instructively compared to other projects. Microcomputer kits such as the Altair 8800 would not be available for a few years, but digital logic components such as TTL and other ICs had become standard electronics parts.

In November 1971, Intel introduced its first single-chip microprocessor, the 4004. Douglas Engelbart, Ted Nelson, and others had already begun to ponder the impact of computing on human potential. Nelson, for example, called for “computer liberation” in *Computer Lib* and proclaimed that everyone “can and must understand computers NOW.”²² He predicted new applications for a variety of purposes and asked, “Can the public learn, in time, what good and beautiful things are possible” from computer systems (pp. 2–3)?²² Nelson’s manifesto included computer games, for he had observed that “wherever there are graphic displays, there is usually a version of the game *Spacewar*.” Citing the 1972 *Rolling Stone* article,¹¹ Nelson might have been looking through Bushnell’s eyes when he remarked that “games with computer programs are universally enjoyed in the computer community” (p. 48)²² He discussed computer games at about the same time as Bushnell began working on *Computer Space*, specifically mentioning versions of Conway’s *The Game of Life*²³ and BASIC programs published by the People’s Computer Company, an organization near Stanford University (and Ampex) that sought to bring programming power to the people through recreational and educational software. Nelson provided a voice for those who

proposed to move advanced text, graphics, networking, and other computer technologies out of academic laboratories to make them available to everyone. Bushnell took the engineer’s route as he thought about building a machine on which anyone could play a version of *Spacewar*.²⁴

As Bushnell worked on *Computer Space* during 1971, he might have been aware of other projects like his. In 1969, Rick Blomme had written a two-player version of *Spacewar* for the Programmed Logic for Automatic Teaching Operations (PLATO) time-sharing system at the University of Illinois. It was the first multiplayer game hosted by the PLATO project, which during the 1970s became a hotbed for innovative, networked games.²⁵

As he was completing *Computer Space*, Bushnell probably heard about a summer project closer to home; a recently graduated SAIL student, Bill Pitts, and his friend Hugh Tuck built a coin-operated (coin-op) computer game, *The Galaxy Game*, for the newly released PDP-11/20, DEC’s first 16-bit computer. DEC had fit the PDP-11 into a relatively small box and listed it for a mere \$20,000, hoping to open new markets and applications.²⁶ Pitts and Tuck formed a company called Computer Recreations, bought the low-end version of the PDP-11 for only \$13,000, and converted the PDP-10 version of *Spacewar* for this machine. Including a Hewlett-Packard vector display, wooden cabinet, and other parts, their expenses came to roughly \$20,000. In September 1971, they installed it in Stanford’s student union, where a later version that supported up to four monitors (eight players) could be found until 1979. *The Galaxy Game* was faithful not only to *Spacewar*, but also to the player community (university students and computer engineers) and to the technical configuration (software code, vector displays, time-sharing, and so on) that produced it.²⁷

Bushnell started out on the same course of programming a version of *Spacewar*. Like Pitts and Tuck, his first thought was to purchase an inexpensive minicomputer, maybe the new Data General Nova or the SuperNova.²⁸ Instead of coupling the computer to expensive monitors, he would link up several game stations equipped with cheap, off-the-shelf TV sets using raster, not vector, graphics.²⁹ At first, Bushnell knew almost nothing about how TV sets might function as monitors, but Dabney brought him up-to-speed quickly on TV signal generation and related topics. Indeed, Dabney showed Bushnell how to

modify a TV using TTL components to move an object around on the screen.³⁰

This promising union of technologies—the computer from the university lab and the TV from the home—proved impractical, however. There was little chance of getting the design to work with the equipment available, and no chance to do so at an acceptable cost. According to Bushnell, the burden of providing images to multiple TV monitors would bring a computer to its knees; it would be “blindingly slow” even if Dabney and Bushnell were able to tweak monitors and build circuitry to offload processing from the CPU.¹⁷

Dabney certainly grasped quickly that computers designed to drive vector displays could not be used to produce raster-scan output for analog TV monitors. Bushnell’s telling of the story suggests that they were able to lash up parts of a working system, but it is clear that the original concept was abandoned quickly. According to Al Alcorn, Bushnell’s wife was responsible for ordering the computer but considered the price tag for the computer “crazy” and never ordered it.

Frustrated by the likelihood of poor performance and fuzzy images, Bushnell

designed out the need for the computer, because the computers were so slow at that time... So there was this brilliant leap that Nolan made about how he could get rid of just a little bit of logic [and still] do the same thing the computer’s going to do, just much, much faster, so he didn’t need the computer.³¹

Bushnell and Dabney promptly dumped the stillborn idea of a computer controlling multiple raster-scan displays. They replaced the minicomputer with dedicated circuits based on TV technology that controlled all aspects of the game, from game logic and graphics to player controls. Resetting the project made it possible to finish with a working prototype. After sculpting a futuristic cabinet for the arcade console, Bushnell sold *Computer Space* to Nutting Associates, where the design benefited from the contributions of experienced engineers; Bushnell joined the firm as chief engineer to oversee the final design, manufacturing, and distribution. It was released in August 1971.

Even though Nutting went on to build between 1,500 and 2,300 machines,^{6,30} the historical verdict on *Computer Space* has generally been negative, whether with respect to sales, game play, or controls. Videogame historians have written that, besides Bushnell’s friends, “the rest of the world didn’t show

any interest in the game at all” and it “failed,” that it was “unsuccessful,” a “failure,” “lacking in mainframe complexity,” and a “colossal commercial flop.”^{6,17,19,20} Bushnell offers only a weak defense, claiming that it “did okay, but it really didn’t do as well as it could have” or that it did “very well on college campuses and in places where the educational value was higher. However, there weren’t any arcades as such back then.”^{17,20}

Computer Space redeemed itself mostly as a negative example for Bushnell and Al Alcorn when they made the next game and as the first step toward the creation of Atari and *Pong*. From his own mistakes and the work with Nutting Associates, Bushnell learned about game console engineering and, especially, the arcade business. On the positive side, Dabney and Bushnell took away \$500 in royalties from *Computer Space* to start their new company. On the whole, however, *Computer Space* was the failure that motivated *Pong*’s designers to keep things simple the second time around.

Design Lessons from *Computer Space*

These assessments of *Computer Space* miss its significance for the videogame as a technological artifact. It provided more than a learning experience: *Computer Space* established a design philosophy and general technical configuration for arcade consoles,³² and it reduced the laboratory-based computer game to a format that would launch the videogame as a consumer product. When Bushnell noted years later that his engineering friends loved *Computer Space*, even if “the typical guy in the bar” was completely baffled, it is easy to hear echoes of this appreciation in assessments of his technical achievement from engineers, designers, and operators. Most notably, they argued, “The machine is like a historical blueprint of how all arcade games to follow would be made,”³³ and “The brilliance of these machines was that Nolan Bushnell and company took what was computer programming (in *Spacewar*) and translated it into a simpler version of the game (no gravity) using hard-wired logical circuits.”³⁴

The arcade videogame design defined by *Computer Space* was notable on three counts: (1) packaging, both internal and external; (2) optimization; and (3) despite the daunting complexity of its game play, simplification, especially with respect to service requirements. Because Bushnell’s lovingly shaped, futuristic cabinet design was visually memorable, good

HOW COMPUTER SPACE WORKS AND PRODUCES

BEAUTIFUL SPACE-AGE CABINET attracts players of all age groups. The player is additionally attracted by two flying saucers moving about in formation on the playfield while the unit is in its non-activated state.

EXCITING PLAYER ACTION occurs as coin is inserted and start button is pushed to activate the unit. A rocket ship appears out of nowhere and at the same instant the once friendly flying saucer begins firing missiles at the rocket ship. Now at the controls of the rocket ship, you begin to evade the missiles bearing down on you and maneuver into position to fire your own missiles at the saucers. The thrust motors from your rocket ship, the rocket turning signals, the firing of your missiles and explosions fill the air with the sights and sounds of combat as you battle against the saucers for the highest score. Outscore or hit the saucers with your missiles more times than they hit you for extended play in hyperspace. Attain hyperspace and the playfield turns white and gives you a vision of daylight in outer space. Thrill to the reality of controlling your own rocket ship in gravity-free outer space. Battle the saucers in a duel of wits and coordination!

HOW COMPUTER SPACE WORKS AND PRODUCES

CHECK THESE UNIQUE FEATURES

- ★ Coin acceptor, rocket thrust button and rocket steering controls are the only moving parts in the entire unit. No mechanical relays, films or belts.
- ★ Adjustable play time from 1 minute to 2½ minutes.
- ★ Standard unit 25¢ play convertible to 2/25¢ by the throw of a switch.
- ★ Tamper-proof coin meter.
- ★ Continuous blinking panel lights and back-lit playfield for player attraction.
- ★ Integrated circuits in low-current solid-state construction insure the ultimate in long life.
- ★ No repeating sequence; each game is different for longer location life.

COMPONENTS? THERE ARE ONLY THREE ASSEMBLIES IN THE ENTIRE UNIT

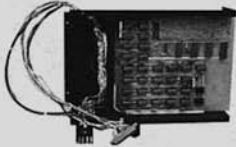

Computer (Brain Box)



Front Control Panel



Black and White TV Set

COMPUTER (BRAIN BOX) is sealed and carries a full one-year unconditional guarantee if not tampered with. FRONT CONTROL PANEL houses the only moving parts in the unit—the rocket ship controls and coin acceptor. BLACK AND WHITE TV SET has the life of any new black and white receiver—no modifications have been made to affect its reliability.

Weight 98 lbs.; Dimensions 30" wide x 67" high x 30" deep.

NA NUTTING ASSOCIATES, INC.
500 LOGUE AVE., MOUNTAIN VIEW, CA 94040 (415) 961-9373

Distributed By

11-71-208 PRINTED IN U.S.A.

Figure 3. Nutting Associates' instructions for Computer Space.

enough to serve as a prop in Hollywood movies such as *Soylent Green* (1973) and *Jaws* (1975), it is easy to forget that this technical configuration of *Computer Space* would remain essentially unchanged for a generation of coin-op arcade consoles. Bushnell divided his machine into component modules. Nutting's sales flyer, probably authored by Bushnell, crowed that there were "only three assemblies in the entire unit": a modified General Electric black-and-white

TV set, the front control panel, and the "computer (brain box)." Circuitry, control, and screen were set into the "beautiful space-age cabinet" with a few other parts, such as a power supply and coin acceptor (see Figure 3).³⁵

In *Computer Space*, physical modules in the form of ICs mounted on three printed circuit boards replaced programs and executed game logic in hardware. Bushnell's original concept of a configuration of several raster

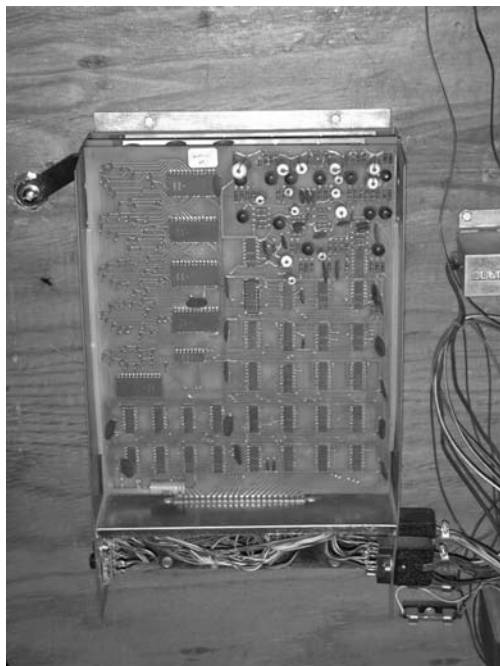

Figure 4. Circuit board, possibly from Computer Space, serial number 1. (Courtesy of <http://www.computerspacefan.com/SN1large.htm>)

displays connected to a computer was a failure, so he and Dabney replaced software with electronic components and ICs such as Texas Instruments' 7400 series of TTL circuits. At Ampex, they had been surrounded by engineers (like Al Alcorn) busy at developing products that utilized TTL technology. It was natural to consider how physical logic elements like flip-flops, counters, and registers could provide the synchronization signals needed to display graphical elements and scores, the creation of on-screen symbols, or execution of game logic.³⁶ For example, a small number of diode arrays connected to logic gates produced the rotating images of rockets seen on the screen; the rocket images were clearly visible even in the pattern of diodes on one of the PC boards (see Figure 4).

It is tempting to think of these diode arrays as precursors of game ROMs, but this conception reintroduces the notion of program code, exactly what Bushnell and Dabney eliminated from the design. Bushnell's rockets were essentially hardwired bitmaps that could be moved around the screen independently of the background, a crucial innovation that made it possible to produce screen images efficiently. He called these moving images *patches*. The design concept would become part of Atari's shared knowledge; even if "nobody could ever understand Nolan's

schematic, ... it was the idea of taking the bitmap in a little area that could be moved around so that it would not be necessary to redraw an entire screen every time an image moved" that every Atari engineer understood.³⁷ Bushnell's patch solution eventually became a staple of game machines and home computers in the form of *sprites*, the term taken from Seymour Papert's briefly popular Logo programming language after a new generation of Texas Instruments graphics chips put it into home computers during the late 1970s.

The idea of taking a game design and making it "more efficient in silicon" persisted in the design of dedicated and programmable game machines such as the Atari 2600 VCS, with the Stella custom graphics chip, even after the introduction of microprocessor control and program storage in ROM;³⁸ sprites were an important feature of home computers such as the Atari 400/800 (as "player/missile graphics" or "motion objects") or the Texas Instruments TI99/4A. The cost of expensive microprocessors could not be justified for home machines as they could for arcade consoles through much of the 1970s. Hence, Atari's original coin-op design philosophy was carried on in the design of home machines, reducing the workload on slow central processors by using specialized graphics hardware.

Because the main criticism leveled at *Computer Space* has been the daunting complexity of game controls and game play, Bushnell's efforts to keep the design of the arcade console as simple as possible have been overlooked.³⁹ His goal was to ensure reliability and ease servicing of delivered units. As he put it in a sales flyer, it was "our object to create a new standard of reliability using the latest technology. We believe that this goal has been met ... *Computer Space* requires operators to have no more fear of replacing a bad tube than of replacing a bad relay." Because it was built with solid-state circuits, the manufacturers could boast that *Computer Space* had "no mechanical relays, films, or belts" to repair, the only moving parts being the coin acceptor and player controls. Bushnell reminded operators that the display was an ordinary TV set with "no modifications to affect its reliability." It would be "no harder to adjust than any home receiver."

It is worth noting that he played both ends of the stick by designating the internal hardware circuits mounted on PC boards as the "computer." By doing so, he recalled the origins of the game and created a space age aura around it, but on the other hand, he

demarcated the “brain box” as a no-touch zone, a black box, by telling operators that it carried an “unconditional guarantee” only “if not tampered with.”³⁵

Atari and Pong

When it became obvious that *Computer Space* would not be a hit in arcades, Bushnell and Dabney severed their relationship with Nutting and founded Syzygy/Atari in June 1972. Before long, they were joined by another talented Ampex engineer, Al Alcorn, who had studied electrical engineering and computer science at the University of California, Berkeley, and since 1968 refined his skills in video and analog engineering at Ampex.⁴⁰ Alcorn was particularly skilled at applying his knowledge of transistor logic and ICs to “analog problems.” Busy with the two-player version of *Computer Space*, Bushnell assigned Alcorn the task of designing a simple home-consumer game based on Ping-Pong. He inspired the new employee with a story that Atari had a buyer for the game—General Electric, no less. Bushnell failed to mention that he had almost certainly taken the idea from playing a similar game earlier that year on the new Magnavox Odyssey TV game console.^{9,31} Concerned that it was “too big a step for [Alcorn] to go from not knowing what a video game was” to designing a real game, Bushnell’s ruse set up a training exercise through which he eased Alcorn into electronic games. So Bushnell came up with “the simplest game I could think of, which was a tennis game.” According to Alcorn, he understood the task as simply, “let’s just do the most simple game to save time.”³¹

In fact, no such contract existed, but Alcorn rose to the challenge and proved his mettle as an engineer. With his previous job experience and training, he was thoroughly familiar with state-of-the-art electronic components such as TTL ICs. The project also demonstrated his mastery of TV electronics. And last but not least, he distilled value from Bushnell’s ideas and suggestions, which were as often chaotic as enlightening. Even though he could not decipher the schematics Bushnell showed him of *Computer Space*, Alcorn recalls:

Nolan had filed a patent on the fundamental trick: ... how to make a spot appear on a TV screen like Pong without having to do a memory map, a frame buffer, like what you would do today, because there was no memory other than flip flops. And so it was a very, very, very clever trick. I think I perused, glanced at the patent and [learned verbally] from Nolan



Figure 5. Pong prototype. (Photographs courtesy of Al Alcorn.)

how it was done; it was really clever. It involved simply making a ... television sync generator which had counters to count clock pulses to make a horizontal sync, and then counters to count horizontal sync to make vertical sync, and so you’d get the lines set up. If you had another sync generator and you just had it running at the same time, but not synchronous with it, just the same clock and you decided to take the second sync generator output and make a spot where horizontal and vertical sync happen at the same time, that spot would appear randomly, somewhere on that screen, just by happenstance. ... it was this happy relationship between using the digital TTL circuits, which are absolutely ones and zeros, to do video which in those days was absolutely analog.^{41,42}

Within a few months, Alcorn produced a prototype from a store-bought TV set, a homemade cabinet, about 75 TTL ICs, and some tricks from his bag of analog and television engineering (see Figures 5 and 6).

THE NEWEST ² PLAYER
VIDEO SKILL GAME

PONG

from ATARI CORPORATION
SYZYGY ENGINEERED

The Team That Pioneered Video Technology

FEATURES

- STRIKING Attract Mode
- Ball Serves Automatically
- Realistic Sounds of Ball Bouncing, Striking Paddle
- Simple to Operate Controls
- ALL SOLID STATE TV and Components for Long, Rugged Life
- ONE YEAR COMPUTER WARRANTY
- Proven HIGH PROFITS in Location After Location
- Low Key Cabinet, Suitable for Sophisticated Locations
- 25¢ per play

THIS GAME IS AVAILABLE FROM YOUR LOCAL DISTRIBUTOR

Manufactured by
ATARI, INC.
2962 SCOTT BLVD.
SANTA CLARA, CA.
95050

Maximum Dimensions:
WIDTH - 26"
HEIGHT - 50"
DEPTH - 24"
SHIPPING WEIGHT:
150 Lb.



Figure 6. Atari's coin-op Pong machine.

Surprisingly, Alcorn was at first disappointed by his effort because the “criterion then was cost, cost, cost,” and he felt that the final chip count was too high. Bushnell and Alcorn named it *Pong* and installed the coin-op prototype in [Andy Capp's Tavern](#), a local bar where eager players lined up to stuff quarters into the game.^{5,6,17,18,20,41,43}

As I noted earlier, *Pong's* triumph has been credited to the unrepentant simplicity of its

design. Three short sentences on the cabinet's faceplate told players everything they needed to know: put a quarter into the machine, a “ball” will be served; move the paddle to hit the ball back and forth. Alcorn felt instructions were unnecessary altogether, but Bushnell insisted on them, so in a semi-sarcastic spirit, Alcorn responded by putting on the faceplate a simple summation that became the motto of the new game: “[Avoid](#)

missing ball for high score.”⁴¹ *Pong* owed much of its success to breaking with the complexity of *Computer Space* and *Spacewar* in a manner suited to bar patrons. Unlike *Computer Space*'s beautiful fiberglass cabinet, the *Pong* prototype was set in an ugly square box covered with orange paint and wood veneer, with a simple faceplate for control knobs and instructions. In game play and aesthetics, *Pong* and *Computer Space* were polar opposites.

As an engineering design, however, *Pong* followed *Computer Space* in its modularization and optimization of hardware. Compared to Bushnell, Alcorn was better prepared by experience and inclination to build an efficiently engineered arcade console in three respects:

- He built his game with TV technology from the ground up.
- He deftly used digital components to solve the analog problem of mastering TV output, precisely Alcorn's special domain of engineering knowledge.
- The images required for the game were relatively simple. Unlike the oddly shaped objects such as spaceships in *Computer Space* that required ad hoc memory solutions such as diode arrays, the ball, paddle, and other images in *Pong* were all based on simple rectangles that digital TV circuits could easily generate on the fly.

This last point was especially important. Not a single line of software code was involved in the construction of *Pong*. Like *Computer Space*, *Pong*'s game logic and control operations were paced by synchronization signals for the rasterized TV display, but Alcorn understood more intuitively than Bushnell how to work with these signals during every cycle of the TV circuits. Because every image was based on rectangles, he could generate them by gating counters, even the seven segments of the score display. Alcorn was thus able to build *Pong* optimally from a modest number of ICs, and he was more obsessed than Bushnell with reducing the parts count. He eliminated unnecessary parts not only to make the game run more efficiently, but also to reduce the final product cost. Bushnell's original assignment for a simple home console game explains Alcorn's concern that the prototype even had 75 TTL circuits “and would cost way too much for a high volume home machine.” His single-minded attention to optimization of the electronic circuitry continued the legacy of

Computer Space and remained in Atari's engineering culture through the 1970s.^{37,43,44}

The technology lineage leading from *Spacewar* through *Computer Space* to *Pong* is one way to narrate the complicated historical relationship between the computer and the videogame. *Computer Space* and *Pong* were both TV games in the sense that their designers applied techniques of television engineering to make them, and in fact they required a television to operate. Yet, Bushnell's project emerged from the computer space of academic laboratories and large-scale computers, while *Pong* was cut loose from this mooring. In this telling of the story, arcade consoles, the home game foreshadowed in Alcorn's original *Pong* design, and home consoles created during the mid-1970s—including Atari's home version of *Pong* (1975), General Instruments AY-3-8500 “TV game on a chip” (1976), and the microprocessor- and ROM-based Atari 2600 (1977)—solved Bushnell's problem of reducing the computer game to a configuration suitable for delivery as an entertainment product to mass markets.

Atari never gave up on the computer game, however. When Bushnell first assigned Alcorn to the apocryphal GE project, his long-range goal was still to produce games that were “more complex ... not something simpler” after Alcorn's trial by fire.²⁰ Atari's misleading advertising encouraged the view that videogames were an ambitious coupling of the computer and TV technology (see Figure 7). The company's early marketing literature characterized games like *Pong* as “video computer games” and claimed to having revolutionized the industry “when we harnessed digital computers and video technology to the amusement game field with *Pong*.”⁴⁵

***Pong* as a television game**

Narrating the history of *Pong* as a kind of hyperspace jump from computer space contradicts what has been described as the real story behind videogames and, ironically, as the *Pong* story. This story begins with the notion of the videogame as “an apparatus that displays games using RASTER VIDEO equipment,” not with inspiration from computer games (see <http://www.pong-story.com>). The inventor of this TV game console was Ralph Baer, a television engineer at the military electronics firm Sanders Associates. Indisputably, in 1966 he designed circuitry to display and control moving dots on a television screen, leading to a simple chase game

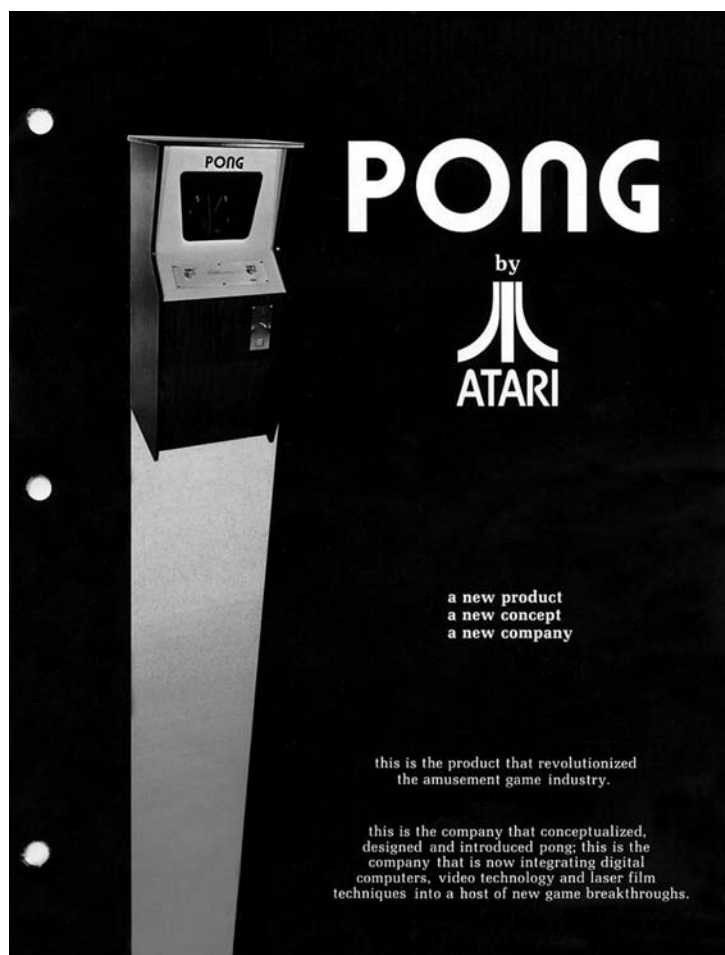

Figure 7. Pong advertising depicting Atari as a high-tech company.

called *Fox and Hounds* based on his original idea for a home television game. After proving the concept by designing several chase and light-gun games, he received permission from Sanders management to continue his TV Game Project. With two coworkers, Baer improved the game system, leading in 1968 to a seventh version called *the Brown Box*, a solid-state prototype for a videogame console (see Figure 8). The Brown Box offered handball and light-gun shooting games, in addition to the original chase games and a ping-pong game. Sanders licensed the



Figure 8. The Brown Box with shooting rifle.

technology and patent rights to Magnavox, and by mid-1971, a working prototype of what would be marketed as the Magnavox Odyssey console was available for consumer testing. Sanders was awarded several US patents for the technology developed by the TV Game Project in 1972, the same year in which Magnavox began selling the Odyssey—the first commercial TV game console for the home.⁴⁶

Bushnell attended a presentation of the Odyssey in Burlingame, California, on 24 May 1972. Working for Nutting at the time, he viewed and played the Odyssey at the demonstration. When he tasked Alcorn with a ball-and-paddle game, his suggestion must have been influenced by what he had seen from Magnavox (pp. 5–9, 76–82).⁹ This version of the Pong story rebuts the construction of the videogame as emerging entirely through Bushnell’s engineering of the computer game.

Baer saw the videogame as an enhanced, interactive form of television, a key motivation for his project at Sanders Associates. Baer’s inspiration thus differed markedly from Bushnell’s encounters with computer games. Situating *Pong* in computer space complicates the “keep it simple” version of its success story. A version of this story that includes Baer’s seminal role in TV game technology must take note not only of the connection between the Odyssey and *Pong*, but also of the differences between their approaches to the problem of designing videogames:

Mr. Bushnell did indeed play the Magnavox Odyssey’s Ping-Pong game hands-on. He clearly needed no instructions on how to play that game. On the other hand, his much more elaborate Computer Space game was failing in the marketplace because it was too complicated to play. A light bulb may have gone on in Mr. Bushnell’s head the moment he played ping-pong on the Odyssey: “Keep it simple.” Complicated games may work for nerds but not for ordinary people. (pp. 5–6)⁹

The failure of *Computer Space* provided the motivation for adopting a design philosophy evident in Baer’s “television gaming apparatus.” Inspired by computer technology, Bushnell adopted the TV game as the basis for the success of Atari’s coin-op console.

After the 1975 Christmas season, a *Business Week* reporter wrote that “at the moment, only two companies are serious factors in consumer electronic games:” Atari and Magnavox.⁴⁷ Ten years later, the videogame industry had crashed, burned, and risen

again under the new regime of Nintendo's carefully crafted protection of the technical platform, intellectual property, and content of videogames. Nintendo's strategy was zealous control of its technology and products. It staved off competition by using legal, business, and technical means to screen and occasionally block independent software developers from access to its hardware: the *Famicom* (1983) and its American version, the *Nintendo Entertainment System* (1985).

Magnavox and Sanders by then were in the habit of tenaciously defending their patents. They had litigated effectively against a virtual who's who of the game industry.⁴⁸ A clash was inevitable. As early as 1975, Nintendo had declined Magnavox's offer of a license for TV game technology; a year later in correspondence with Sanders, Nintendo's representative noted a "conflict" with the "concept of Mr. Nolan K. Bushnell," but apparently without knowledge of the licensing agreement that existed between Atari and Magnavox.⁴⁹

More than a decade later, after the introduction of the NES, Nintendo decided to fight the Sanders-Magnavox patents. Conflating the Atari and Baer versions of the *Pong* story, Nintendo's lawyers tried to convince the court that the Sanders patents had been preceded by *Spacewar*. They insisted that the Sanders team must have known about *Spacewar*—a Magnavox patent lawyer had probably seen the game but failed to inform the Patent Office about it, a Sanders engineer had played it at Stanford and later installed a version on a Sanders computer, or they must have read a description of the game in the *Rolling Stone* article or the book *II Cybernetic Frontiers* (Random House, 1974). Nintendo brought in expert witnesses to state that a person "reasonably conversant in the field" would have been able to convert *Spacewar* for a raster-scan display. Nintendo skirted over the difficulties Bushnell encountered in attempting to realize this idea, with its lawyers asserting that the electronic circuitry for a rasterized computer game would have been relatively standard.⁵⁰ The dispute was brought before New York Federal District Court Judge Leonard B. Sands, but before the case could be adjudicated, Nintendo realized the futility of its claims against Magnavox and settled out of court in April 1991.⁵¹

Conclusion

The lesson of *Pong*'s historical journey through computer space is that invention stories are never as simple as a game of *Pong*.

Nolan Bushnell's *Computer Space* leads to *Pong* as a product inspired by computer technology but practically realized by TV technology. The result was the coin-op videogame console. Baer's TV game apparatus provides a story about who was first to invent the home TV game as a technical, legal, and financial matter (p. 14).⁹

In later years, Bushnell acknowledged the Odyssey, but he unfairly dismissed its significance as being only an analog game. His historical judgment was more accurate when he admitted, "I feel in some way that I didn't invent the video game—I commercialized it. The real digital game was invented by a few guys who programmed PDP-1s at MIT."⁵²

Acknowledgments

I thank Ralph Baer, the inventor of the original videogame console, for his comments and suggestions based on an earlier draft of this article, particularly with regard to arguments made in lawsuits related to infringements on the original patents and licenses and how these arguments might have distorted accounts of the early development of the TV console game. I also thank Allan Alcorn, *Pong*'s designer, for reading an early draft of this article and for many conversations about his work and career, including a recent oral history interview.

References and notes

1. I use the more traditional *Spacewar!* on the first reference and then drop the exclamation point thereafter to avoid any awkward sentence punctuation.
2. For example, H. Lowood, "A Brief Biography of Computer Games," *Playing Video Games: Motives, Responses and Consequences*, P. Vorderer and J. Bryant, eds., Lawrence Erlbaum, 2006, pp. 25–41, and P. Ceruzzi, *A History of Modern Computing*, MIT Press, 1998, pp. 207–210.
3. B. Sutton-Smith, *Toys as Culture*, Gardner, 1986, p. 64.
4. A. Alcorn, "Simplified Block Diagram Pong," PowerPoint presentation and lecture, Stanford Univ., 13 Jan. 2005.
5. G.R. Loftus and E.F. Loftus, *Mind at Play: The Psychology of Video Games*, Basic, 1983, pp. 6–7, and M. Malone, *The Big Score: The Billion-Dollar Story of Silicon Valley*, Doubleday, 1985, p. 343.
6. L. Herman, *Phoenix: The Fall and Rise of Videogames*, 3rd ed., Rolenta, 2001, pp. 11–15.
7. Two terms used throughout this article require some clarification. *Videogame* refers to console games produced for display on televisions and

- early arcade systems, generally raster-scan displays. Likewise, *video* does not in this article have the general meaning of referring to any signal for any display but rather to the specific analog television signal specifications of the 1960s and 1970s—horizontal and vertical sync, color synchronization, and so forth—and thus pertains to television technology specifically.
8. For a quick summary of the major cases in the business history of videogames, see the Patent Arcade website, <http://www.patentarcade.com/2005/05/feature-video-game-lawsuits.html>. See especially *Magnavox Co. v. Activision, Inc.*, WL 9496, 1985 (N.D. Cal.).
 9. R.H. Baer, *Videogames in the Beginning*, Rolenta, 2005. For a list of patents, see pp. 197–220.
 10. K.H. Olsen to P. Elias, “The Story of . . . PDP-1,” internal corporate document, Digital Equipment, 15 Sept. 1961; <http://research.microsoft.com/~gbell/Digital/timeline/pdp-1story.htm>.
 11. S. Russell, quoted in: S. Brand, “SPACEWAR: Fanatic Life and Symbolic Death Among the Computer Bums,” *Rolling Stone*, 7 Dec. 1972; http://www.wheels.org/spacewar/stone/rolling_stone.html.
 12. J.M. Graetz, “The Origin of Spacewar!,” *Creative Computing Video & Arcade Games*, vol. 1, no. 1, Spring 1983, pp. 78–85. This was originally published in *Creative Computing*, Aug. 1981.
 13. D.J. Edwards and J.M. Graetz, “PDP-1 Plays at Spacewar,” *Decuscope*, vol. 1, no. 1, Apr. 1962, pp. 2–4.
 14. G. Bell, “Towards a History of (Personal) Computer Workstations (Draft),” *Proc. ACM Conf. History of Personal Workstations*, ACM Press, 1986, pp. 10–11.
 15. R. Rivlin, *The Algorithmic Image: Graphic Visions of the Computer Age*, Microsoft Press, 1986; as quoted by the Univ. of Utah, “History of the School of Computing,” <http://www.cs.utah/dept/history/>; A.L. Norberg and J.E. O’Neill, *Transforming Computer Technology: Information Processing for the Pentagon, 1962–1986*, Johns Hopkins Univ. Press, 1986, p. 122.
 16. D.C. Hoefler, “Silicon Valley USA,” *Electronic News*, 11 Jan. 1971, p. 3.
 17. R. DeMaria and J.L. Wilson, *High Score: The Illustrated History of Electronic Games*, McGraw Hill/Osborne, 2002, pp. 16–21.
 18. S. Cohen, *Zap! The Rise and Fall of Atari*, McGraw-Hill, 1984, pp. 15–28.
 19. S. Bloom, “The First Golden Age,” *Digital Deli: The Comprehensive, User-Lovable Menu of Computer Lore, Culture, Lifestyles, and Fancy*, Steve Ditlea, ed., Workman, 1984, pp. 327–332; V. Burnham, *Supercade: A Visual History of the Videogame Age, 1971–1984*, MIT Press, 2001, pp. 64–77.
 20. S.L. Kent, *The Ultimate History of Video Games*, Three Rivers Press, 2001, pp. 28–41.
 21. D. Sheff, *Game Over: How Nintendo Conquered the World*, GamePress, 1999, pp. 133–140; P.J. Coughlan and D. Freier, “Competitive Dynamics in Home Video Games (A): The Age of Atari,” *Harvard Business School Industry and Competitive Strategy Cases*, 9-701-091, 12 June 2001, pp. 1–3.
 22. T.H. Nelson, *Computer Lib: You Can and Must Understand Computers Now*, Hugo’s Book Service, 1983, title page & pp. 2–3.
 23. M. Gardner, “The Fantastic Combinations of John Conway’s New Solitaire Game ‘Life,’” *Scientific Am.*, vol. 223, no. 4, 1970, pp. 120–123.
 24. According to Al Alcorn, the Atari group did not hear about Nelson until the late 1970s, and “lots of people had ideas but no one . . . built any working machines” (email correspondence, Aug. 2005).
 25. J. Mulligan, “Talkin’ ‘bout My . . . Generation,” 22 Jan. 2002, http://www.skotos.net/articles/BTH_17.shtml; M. Friedl, *Online Game Interactivity Theory*, Charles River Media, 2003, pp. 4–5.
 26. J.P. Pearson, ed., *Digital at Work: Snapshots from the First Thirty-Five Years*, Digital Equipment, 1992, pp. 58, 65.
 27. B. Pitts, “The Galaxy Game,” 29 Oct. 1997, Computer History Exhibits, Stanford University; <http://www-db.stanford.edu/pub/voy/museum/galaxy.html>. Al Alcorn saw the Galaxy Game on the Stanford campus with Bushnell while collecting quarters from their Pong machine right next to it. Alcorn remembers that “right next to me was Pitts with his, what do you call it, Galaxy Game. And Nolan—we looked at this thing and my goodness, there was a teletype terminal sitting behind it, and he’d be in there modifying code on this thing. There was a vector scan display, from I think Hewlett-Packard or Tektronics, there was a real mini-computer in there.” “Oral History of Al Alcorn. Interviewed by Henry Lowood,” Computer History Museum, X4596.2008, transcript 2, Apr. 2008, p. 3.
 28. In his book *The Ultimate History of Video Games*, Kent, who interviewed Bushnell, refers to “a new and inexpensive Texas Instruments minicomputer” (p. 31). DeMaria and Wilson’s *High Score* reported that Bushnell said, “I originally planned to do it on a Data General 1600,” noting that the cost was \$4,000 (p. 16). Bushnell probably meant the 16-bit Nova 1200, which cost \$3,995 when launched in 1969. Perhaps Kent had in mind Bushnell’s use of the TI 7400 series of TTL integrated circuits, such as the 74150 and 74153 multiplexers shown in the design schematics for the board that controlled graphics and motion of in-game rockets, “B-MEMORY 1 or 2 Player, NA 73-103, Computer Space” (29 Jan. 1973),

- Computer Space Instructions, <http://www.arcadedocs.com/vidmanuals/C/ComputerSpace.pdf>. According to Alcorn, Bushnell's original idea was to use the Supernova minicomputer, which came out soon after the Nova ("Oral History," transcript 1, p. 9).
29. Atari did not use vector-generated images until 1979, when it developed the Digital Vector Generator for the coin-operated games *Lunar Lander* (like Computer Space, formerly a popular computer game in university labs) and *Asteroids*.
 30. L. Herman, "The Untold Atari Story," *Edge*, no. 200, Apr. 2009, pp. 94–99.
 31. "Oral History of Al Alcorn. Interviewed by Henry Lowood," Computer History Museum, X4596.2008, transcript, part 1, Apr. 2008, p. 9–11.
 32. Burnham appreciates this point in *Supercade*, noting that "the game established the basic system architecture for nearly every arcade game to follow," p. 71.
 33. A. Maclean, "Computer Space Restoration"; http://www.ionpool.net/arcade/archuk/computer_space_restoration.html.
 34. L. Kerecman, "Computer Space," Arcade History Database; <http://www.arcade-history.com/?n=computer-space&page=detail&id=3388>.
 35. Nutting Associates, "How Computer Space Works and Produces," flyer, Nov. 1971; N.K. Bushnell, "Computer Space Instructions," typescript, Nutting Associates, Feb. 1972.
 36. On this point, I am indebted to Ralph Baer's comments on an earlier draft of this article.
 37. Videotaped interview with Atari engineers filmed in August 1997: R. Milner and S. Mayer, "Stella at 20: An Atari 2600 Retrospective," videorecording, CyberPuNKS, 2000. See also T.E. Perry and P. Wallich, "Design Case History: The Atari Video Computer System," *IEEE Spectrum*, vol. 20, no. 3, Mar. 1983, pp. 45–51.
 38. Atari's *Tank* (1974) was the first videogame to use ROM for storing game graphics.
 39. He eliminated some details of game play from *Spacewar*, a topic outside this article's scope.
 40. Ampex's role as incubator of talented Silicon Valley engineers and entrepreneurs, such as Ray Dolby, Steve Mayer, Steve Bristow, and Lee Felsenstein, deserves study.
 41. "Oral History of Al Alcorn. Interviewed by Henry Lowood," Computer History Museum, X4596.2008, transcript 2, Apr. 2008, pp. 2–6.
 42. N. Bushnell, *Video Image Positioning Control System for Amusement Device*, US patent 3,793,483, 19 Feb. 1974. The patent was actually filed on 24 Nov. 1972, shortly after Alcorn began work on Pong.
 43. Vintage Gaming Network, "Al Alcorn Interview," Vintage Gaming; <http://atari.vg-network.com/aainterview.html>; D. Owen, "The Second Coming of Nolan Bushnell," *Playboy*, June 1983.
 44. Steve Wozniak's reduction of the TTL count for Atari's *Breakout* game provides a famous example. See also O.W. Linzmayer, *Apple Confidential: The Real Story of Apple Computer, Inc.*, No Starch Press, 1999, pp. 17–20.
 45. Atari Inc., "Atari Expands Worldwide!" flyer, Arcade Flyer Database, 1972; <http://www.arcadeflyers.com/?page=thumbs&db=videodb&id=3303>. In the early 1980s, Atari invested heavily in the game machine as home computer in the form of the Atari 400/800.
 46. Notably, *Television Gaming Apparatus*, US patent 3,659, 285, filed 21 Aug. 1969. The details of this story can be found in R. Baer's *Video-games*. Baer deserves great credit for the extensive documentation of his activities during the key period of his work at Sanders, both in his book and by donating his significant collection of papers to the Smithsonian Institution's Lemelson Center Archives. See http://invention.smithsonian.org/resources/fa_baer_index.aspx.
 47. "TV's Hot New Star: The Electronic Game," *Business Week—Industrial Edition*, 29 Dec. 1975, p. 24.
 48. For example, *Magnavox Co. v. Chicago Dynamic Industries*, 201 U.S.P.Q. 25 (N.D. Ill. 1977), and *Magnavox Co. v. Mattel, Inc.*, 216 U.S.P.Q. 28 (N.D. Ill. 1982).
 49. *Nintendo v. Magnavox*, US District Court, Southern District of New York, document 100. NARA Central Plains Region, duplicate photocopies of selected records at Stanford University.
 50. *Nintendo v. Magnavox*, US District Court, Southern District of New York, document 81, p. 18.
 51. *Nintendo v. Magnavox*, "Order of Discontinuance," US District Court, Southern District of New York, document 112.
 52. D. Becker, "The Return of King Pong," interview, CNET News.com, 15 Mar. 2005; http://news.com.com/The+return+of+King+Pong/2008-1043_3-5616047.html.



Henry Lowood is curator for History of Science and Technology Collections in the Stanford University Libraries. He leads the How They Got Game Project in the Stanford Humanities Laboratory and Stanford's Preserving Virtual Worlds Project. His current research and teaching focuses on the history of computer game design and technology. He is also curator of the Machinima Archive and the Archiving Virtual Worlds collection, both permanent repositories hosted by the Internet Archive. Contact him at lowood@stanford.edu.